

VT100 Display Controller

BV4511/2-c

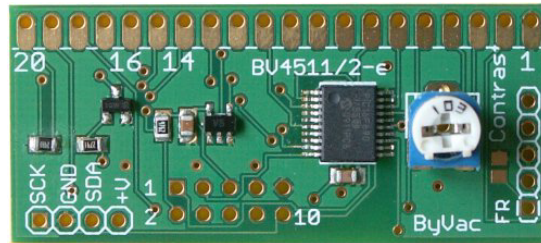

BV4511/2-c VT100 Display Controller

Product specification

Sept. 2009 V0.a

VT100 Display Controller

BV4511/2-c

Contents

1.	Introduction	3
2.	Physical Specification	3
2.1.	External Connections	3
2.2.	Serial Interface	3
2.3.	LCD Interface.....	4

VT100 Display Controller

BV4511/2-c

Rev	Change
September 2009	Preliminary

1. Introduction

This is the controller board as fitted to the BV4511 (VT100) and BV4512 (I2C) Graphics display.

It is designed for that particular display but as the display is a popular make and based on the KS0108B controller then it is quite likely to fit a range of devices.

This datasheet describes the electrical interface for both types of display. For details of how the firmware works please refer to the BV4511 or BV4512 datasheets.

2. Physical Specification

The BV4511/2 is a complete display controller that provides a simple serial interface. The interface is VT100 for the BV4511-c and I2C for the BV4512-c.

Although the physical specification is very similar the boards behave in completely different ways from each other, this is determined by the firmware.

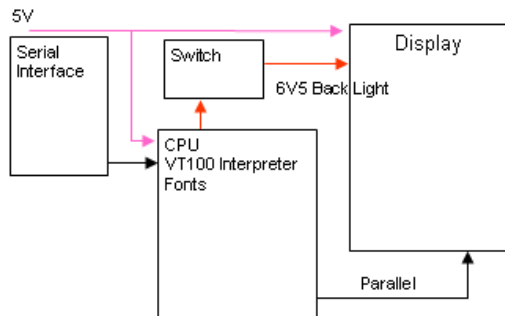

Block Diagram

Display

The controller is designed for a standard 128 x 64 LCD type that contains two KS0108B controllers.

2.1. External Connections

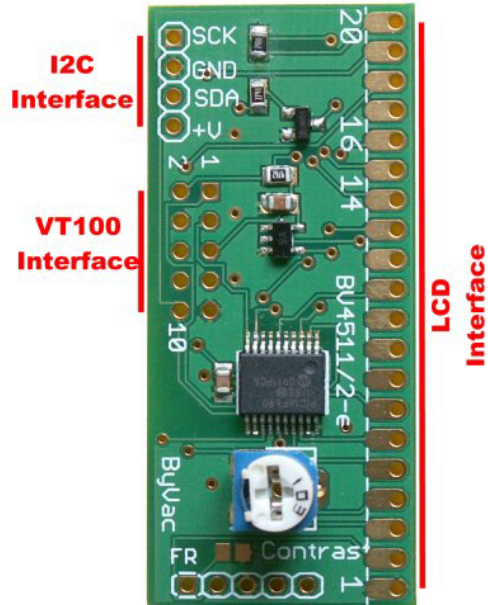

The controller board has three user external connections. Two for the serial interface and one for the LCD interface.

NOTE: The board in the illustration is a generic board that can be either a BV4511-c (VT100) or a BV4512-c (I2C) controller (NOT BOTH). The loaded firmware and a jumper at the back determine what interface the board is. Once programmed the boards CANNOT be interchanged. The user must order either the VT100 or the I2C board.

2.2. Serial Interface

VT100 Interface

The serial connector is a 2x5 pin at the back of the device. Pin 1 is marked with 1. The odd pins are in a horizontal row above the even pins.

Pin	Function	Function	Pin
1	RX	nDD	2
3	TX		4
5	+5V		6
7			8
9	Gnd	nRTS	10

This bVT100 serial connector will mate directly with the BV103. For this device only the TX line is not used as the display does not output any information, it is a read only device.

VT100 Display Controller

BV4511/2-c

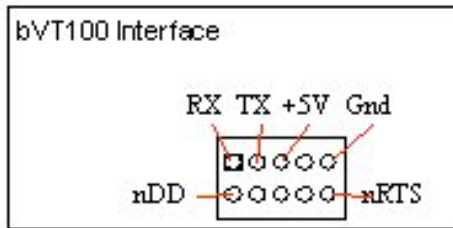

This interface relies on hardware handshaking, without it the device will work but it will not be able to perform at its maximum speed. See the datasheet for the BV4511 display.

I2C Interface

The connection for the I2C interface are clearly marked on the PCB and are above the VT100 interface.

Pin	Name
1	Clock (SCK)
2	GND
3	Data (SDA)
4	+5V

Voltages

The controller board will work from 3.3V to 5V, however the display that will be attached normally requires 5V.

2.3. LCD Interface

The LCD interface runs the full length of the board and on the BV displays it is connected with a pin header.

Pin	Name
1	GND
2	+V
3	VEE [1]
4	RS
5	R/W
6	E
7	D0
8	D1
9	D2
10	D3
11	D4
12	D5
13	D5
14	D7

15	CS1
16	CS2
17	/RST
18	VOUT [1]
19	LED+ [2]
20	LED- [2]

Notes

[1] VEE is connected to the wiper of the 10k Trimmer mounted on the board. One end of the trimmer is connected to GND and the other connected to VOUT

[2] LED+ is connected directly to +V and LED- is connected to a switching transistor via a 33R (nominal) resistor.

If your display does not have the above pin out exactly it is not wise to use this board.